

Andersen “No-Sway” Weight Distribution Hitch

INSTALLATION MANUAL

For all 4” Drop/Rise WD Kits AND all 8” Drop/Rise WD Kits

IMPORTANT! DEALER OR INSTALLER: Please make sure your customer receives this manual for safety tips, warranty, and future removal or installation information

IMPORTANT ALERT: Potential issues may exist when using the Andersen ‘No Sway’ Weight Distribution Hitch with Atwood 88007, 88010, 88555 and 88600 couplers. (For more information, see page 2)



Table of Contents

Important Information and Warnings	Page 2 & 3
Parts Illustration	Page 4
Section 1: Preparation	Page 5
Section 2: Installing Rack & Ball Housing	Page 5
Section 3: Attaching Tension Plate and Chains	Page 6
Section 4: Attaching Frame Brackets to Trailer	Page 7
Section 5: Setting the Tension	Page 11
Section 6: Checking and Adjusting the Tension	Page 11
Troubleshooting	Page 12
Unhooking the Trailer from the Tow Vehicle	Page 12
Hooking the Tow Vehicle back up to the Trailer	Page 13
Popular Add-ons for your Ultimate Connection	Page 14
Warranty Information	Page 15

Want to see a video of the install?



Use your Smart Phone to scan the QR Code above or go to our Installation videos on the web at help.AndersenHitches.com/install

ANDERSEN 

andersenhitches.com

Featuring the patented, super-quiet Anti-Sway and Anti-Bounce TMD (True Motion-Dampening™) system
3”, 2-1/2” & 2” shanks available • 14,000 lbs GTWR (2-5/16” ball) • 10,000 lbs GTWR (2” ball) • 1,400 lbs tongue

100%
USA
MADE  SUPPORT
USA JOBS

NOTE: THERE IS **NEVER** A NEED TO GREASE BALL OR COUPLER

IMPORTANT ALERT!

Potential issues may exist when using the Andersen 'No Sway' Weight Distribution Hitch with Atwood 88007, 88010, 88555 and 88600 couplers. All other Atwood couplers work great.

When these few Atwood couplers are combined with the Andersen Weight Distribution system — and other weight distribution systems — there is a potential issue where some couplers can become unlatched over time due to wear on the internal latch system. This issue is present because of the unique design of the couplers.

To our knowledge, this potential issue ONLY affects the Atwood 88007, 88010, 88555 and 88600 couplers. All other Atwood couplers work great. Older (pre-Atwood) Marvel couplers also work great. Newer models may also encounter these issues if designed in a similar style.

Although we have heard of Atwood coupler users who have had some success with modifying the latch mechanism and greasing the paw and ball, **Andersen Manufacturing does not officially endorse any solution other than replacing the coupler itself with a different Atwood coupler.** (See your local Dealer or contact us for recommendations on a replacement coupler)

Please feel free to contact us if you have further concerns or questions.

Customer Service: 1-800-635-6106
customerservice@anderseninc.com
help.AndersenHitches.com



Using the WD Hitch with late model vehicles that have electronic anti-sway

The Andersen WD Hitch features its own sway controls that are designed to auto-adjust to the load in your trailer and prevent trailer sway when installed properly. Unfortunately, some newer electronic anti-sway systems can misread the anti-sway efforts of the Andersen WD Hitch and the anti-sway system may actually cause the trailer to sway as the two systems work against each other.

These potential issues typically occur with electronic anti-sway systems that are designed to detect trailer sway and automatically use the vehicle brakes to help control the sway. Please note that this type of anti-sway system is different from electronic traction control, which does not cause this type of problem. If you experience this type of issue, you will need to turn off the electronic anti-sway in your vehicle in order to tow with the Andersen WD Hitch.

This issue is most likely to occur in 2011 and newer truck models from Ford, GMC, Dodge, and Chevy. Refer to your tow vehicle's owners manual to determine if you have electronic anti-sway and how to disable it while using the WD Hitch to tow.



IMPORTANT INFORMATION



FOR SAFETY Secure your trailer using wheel chocks before setting up or adjusting the Andersen Weight Distribution Hitch.

The operator is responsible for making necessary adjustments to the weight distribution hitch to maximize performance for each trip and every time the load changes.

REMEMBER Any time you change your load weight in the towing vehicle or trailer, re-check to see how level you are and make adjustments as needed. Also, before each trip — and regularly during a trip — check all hardware, bolts and nuts for wear and fatigue. Make sure that they are all properly tightened and that all pins and clips are secured in place.

It is critical to check the tire pressure of each of the tires on the trailer and tow vehicle before towing.



WARNING



Refer to your vehicle's owners manual for maximum towing capacity. **DO NOT** overload your vehicle — failure to follow vehicle manufacturer's recommendations could result in damage to your vehicle, personal injury or death. **Your combined load and trailer weight should be less than the lowest weight rating of your tires, vehicle, and hitch.** You should also refer to the manufacturer's instructions for your trailer and follow all safety warnings, setup instructions, and maintenance before installing your hitch.

Make sure the trailer coupler is coupled and secured properly before towing, and that safety chains are in place.

Do not modify Weight Distribution Hitch components outside of the recommendations found within this manual. (e.g. shortening/extending chains, welding brackets to the trailer frame, etc.)

IMPORTANT! No hitch setup can guarantee that trailer sway will be avoided altogether. It is the driver's responsibility to adjust equipment and driving habits according to towing conditions. The driver is responsible for their own safety and the safety of passengers and those around them.

NOTE: AS WITH ANY WEIGHT DISTRIBUTION HITCH,
DO NOT USE THE ANDERSEN WD HITCH WITH ANY KIND OF SURGE BRAKE SYSTEM

A NOTE ABOUT SUSPENSION

Ensure that the suspension of both the tow vehicle and trailer are in good working order before you embark on a trip. Bad suspension may result in the Weight Distribution Hitch not being able to properly even out your load. Always load trailer correctly according to the manufacturer's recommendations for maximum weight limits and cargo placement. Do not overload trailer or towing vehicle.

We are proud that our Weight Distribution Hitch is rated up to 1,400 lbs tongue weight to meet the SAE J-684 strength requirements. However, if your trailer tongue weight is pushing 1,400 lbs, we recommend possibly improving or 'beefing up' the suspension of both 1/2 ton and 3/4 ton vehicles.

PARTS ILLUSTRATION – WEIGHT DISTRIBUTION HITCH

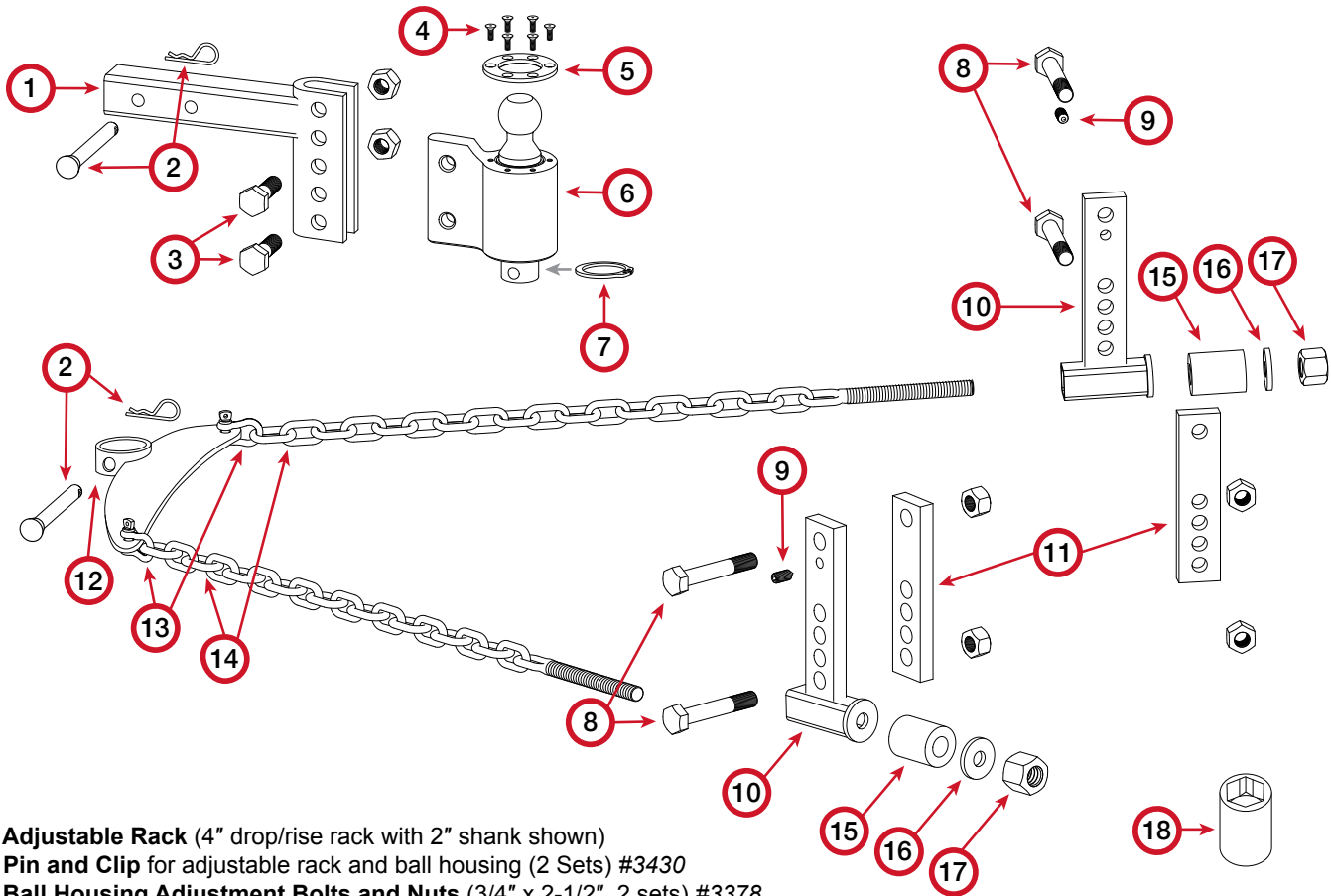

1. Adjustable Rack (4" drop/rise rack with 2" shank shown)
2. Pin and Clip for adjustable rack and ball housing (2 Sets) #3430
3. Ball Housing Adjustment Bolts and Nuts (3/4" x 2-1/2", 2 sets) #3378
4. Ball Housing Plate Screws (6 pcs, attached to ball housing)
5. Ball Housing Plate (attached to ball housing)
6. Ball Housing (includes housing, tapered ball, and brake material cone) #3383, #3355
7. Spring Clip (attached to tapered ball) #3376
8. Frame Bracket Bolts and Nuts (5/8" x 4", 4 sets)
9. 'Pointed' Set Screws (2 or 4 pcs, depending on your specific WD kit)
10. Outside Frame Brackets (2 pcs, universal 3/4"/5"/6" brackets shown)
11. Inside Frame Brackets (2 pcs, universal 3/4"/5"/6" brackets shown)
12. Tension (Triangle) Plate #3356
13. Chain Shackles (2 pcs) #3374
14. Tension Chains with End Bolts (2 pcs) #3357
15. High-Density Urethane Springs (2 pcs) #3358
16. Spring Washers (2 pcs) #3388
17. Tension Nuts (1-1/4", 2 pcs) #3370
18. 1-1/4" Socket #3384

TOOLS NEEDED FOR INSTALLATION

- Measuring Tape
- 5/16" Allen Wrench
- Two 1-1/8" Box End or Adjustable Wrenches
- Two 15/16" Box End or Adjustable Wrenches
- Torque Wrench capable of 150 ft-lbs of torque
- 1-1/4" Socket (provided, fits 1/2" drive)

Possible Add-Ons (see page 14 for more info and products)

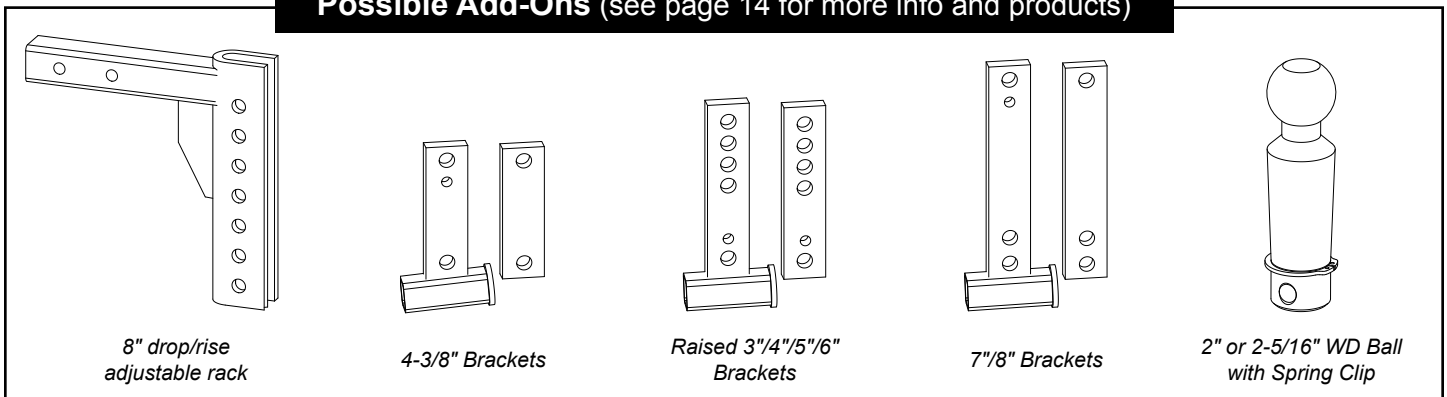

8" drop/rise adjustable rack

4-3/8" Brackets

Raised 3/4"/5"/6" Brackets

7/8" Brackets

2" or 2-5/16" WD Ball with Spring Clip

SECTION 1: PREPARATION

1-1. Start on level ground. If you are planning on hauling ATVs or other heavy equipment, you should load the trailer and tow vehicle with those items beforehand. Follow proper weight distribution guidelines as laid out in the manufacturer's recommendations for the tow vehicle and trailer. Make sure to stay within the limitations of each manufacturer's maximum weight recommendations.

IMPORTANT! When possible, make sure that any auto-leveling system is disabled or turned OFF temporarily during installation.

1-2. Ensure that the trailer is parallel to the ground by comparing measurements (A) and (B) — i.e. from the ground to the frame on both the front and back of the trailer.

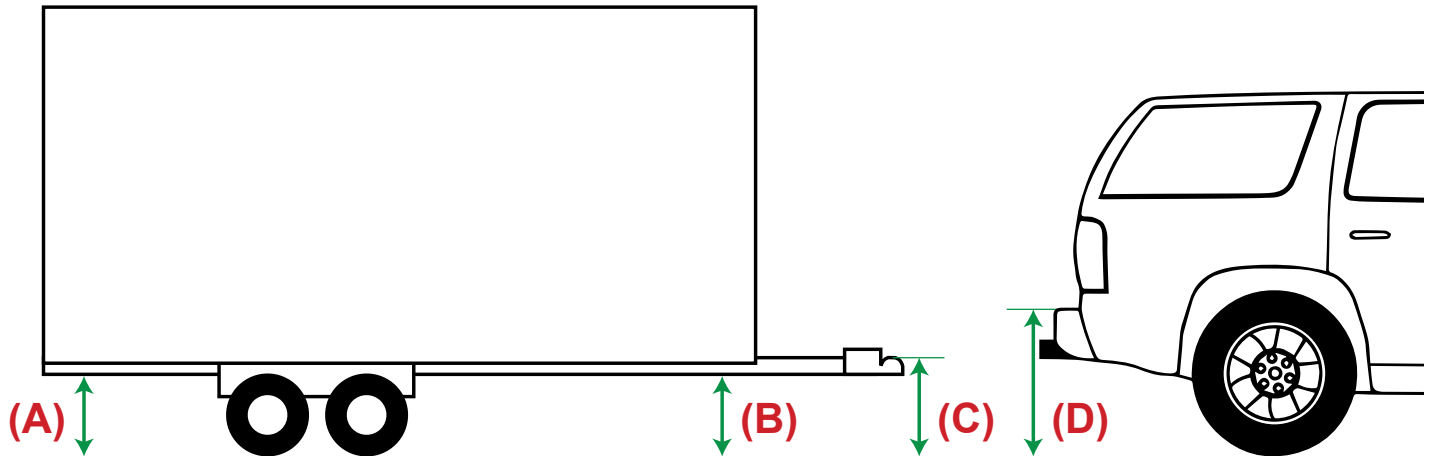

SECTION 2: INSTALLING THE RACK AND BALL HOUSING (SWAY CONTROL)

2-1. Once the trailer is level, place the adjustable rack into the hitch receiver on your towing vehicle. Secure it to the receiver using the standard pin and clip (provided) or your own locking pin.

(Optional locking receiver pin available from Andersen - Part #3429)

2-2. Place the Ball Housing into the adjustable rack so that the top of the ball is about 1" to 1-1/2" higher than the top of the trailer's coupler (C).

2-3. Place the two ball housing adjustment bolts through the holes in the rack and Ball Housing unit to hold it in place (you will tighten the adjustment bolt nuts in step 3-1). **At this time, you will want to measure the height of your tow vehicle bumper (D) for use in step 3-4.**

2-4. Raise the tongue of the trailer up high enough so that the ball mount can comfortably fit under the trailer coupler. Back your tow vehicle up so that the ball mount is directly under the trailer coupler and then set the FULL WEIGHT of the trailer down on the ball.

The front end of your trailer should now be about 1" to 1-1/2" lower than the back. If the front of the trailer is **MORE** than 1-1/2" lower than the back, you might need to raise the trailer coupler off of the Ball Housing and move the Ball Housing up a notch or two so that it is close to level (i.e. within 1-1/2" difference).



DO NOT GREASE THE BALL OR COUPLER! Since the ball and coupler move together, there is no friction that would create a need for grease, and any grease that works its way into the ball housing can decrease the anti-sway abilities of the Andersen WD Hitch.

SECTION 3: ATTACHING THE TENSION PLATE AND CHAINS

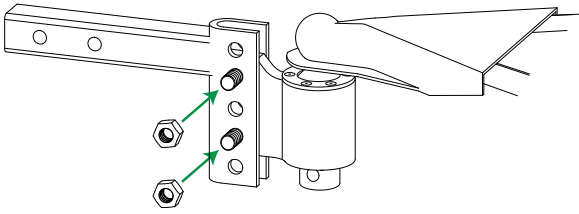

3-1. Raise the trailer up so there is almost no weight on the ball. Next, place the two nuts onto the ball housing adjustment bolts and tighten to approximately 150 ft-lbs of torque using two 1-1/8" sockets or wrenches. This will squeeze the sides of the adjustable rack around the Ball Housing. Then, use the coupler latch to lock the trailer coupler onto the ball.

IMPORTANT! For this part of the installation, make sure there is **ALMOST NO WEIGHT** being placed on the ball when you lock the trailer coupler in place on the ball.

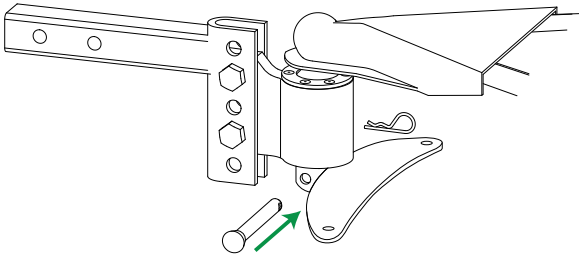

3-2. Attach the Tension Plate to the bottom of the Ball Housing by securing it in place using the pin and clip provided (see left). If you want to, you can use our locking receiver pin (Part #3429) for this purpose as well.

3-3. Look at a bird's-eye-view of the Tension Plate (see below) to make sure that the Tension Plate is close to perpendicular to the trailer frame (fig. 3-1). If not, raise the trailer jack off the ground and use the tow vehicle to move the Trailer forward or backward at an angle until the plate is close to perpendicular to the trailer frame (fig. 3-3). **NOTE: The plate does NOT need to be perfectly perpendicular, a little off of perpendicular is fine.**

IMPORTANT: DO NOT USE A HAMMER TO TRY AND LINE THE PLATE UP.

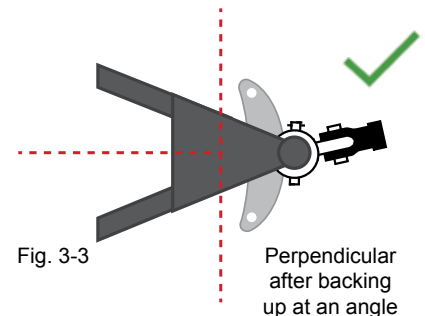
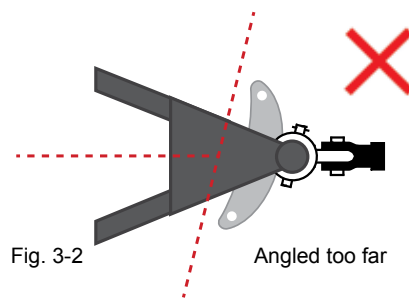
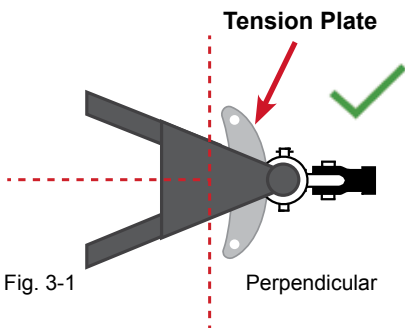

IMPORTANT: DO NOT USE A HAMMER TO TRY AND LINE THE PLATE UP, IT WILL DAMAGE THE PLATE

3-4. With your trailer coupler locked and secured to the ball, extend your jack and RAISE THE TRAILER an inch or two above the bumper height measurement (D) taken in installation step 2-3. This ensures that the coupler is pulling up on the ball (which will also raise the WD rack and the back of your vehicle). **Leave the trailer in this raised position while you continue with the following steps.**

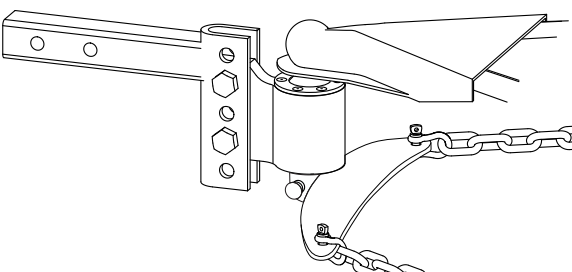

3-5. Attach the chain shackles to the Tension (Triangle) Plate by threading the shackle pin through the hole on the plate (everything should look like the diagram on the left).

3-6. Hand-tighten both shackle pins until they are fully seated.

SECTION 4: ATTACHING THE FRAME BRACKETS TO THE TRAILER

4-1. With the TRAILER STILL RAISED, attach both tension chains to the outside frame brackets using the hardware shown below.

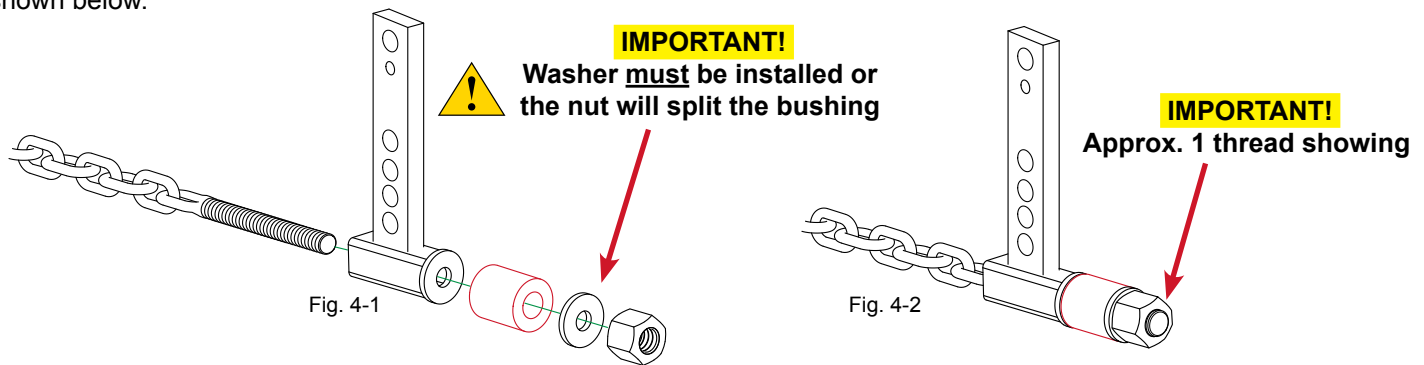

1. Insert the chain bolt into the SQUARE opening of the outside frame bracket (DO NOT thread it through the round "washer" side first). Make sure the chain is not twisted.
2. Place the red high-density urethane spring onto the protruding bolt.
3. Place the washer on the bolt (Fig. 4-1).
4. Thread the Tension Nut on the bolt until approximately 1 bolt thread is protruding from the end (Fig. 4-2).

4-2. Pull the chains tight to get an idea of where the brackets will touch the frame and check for any obstructions or wiring that might be in the way. With one thread showing at the end of the tension nut, the frame brackets will touch the frame at approximately 28" or 29". See page 10 for bracket placement on 'Y' Style Trailer Frames.

IMPORTANT! Since each set up can be different, only use this MEASUREMENT as an approximate position to look for obstructions, NOT for pre-installing brackets.

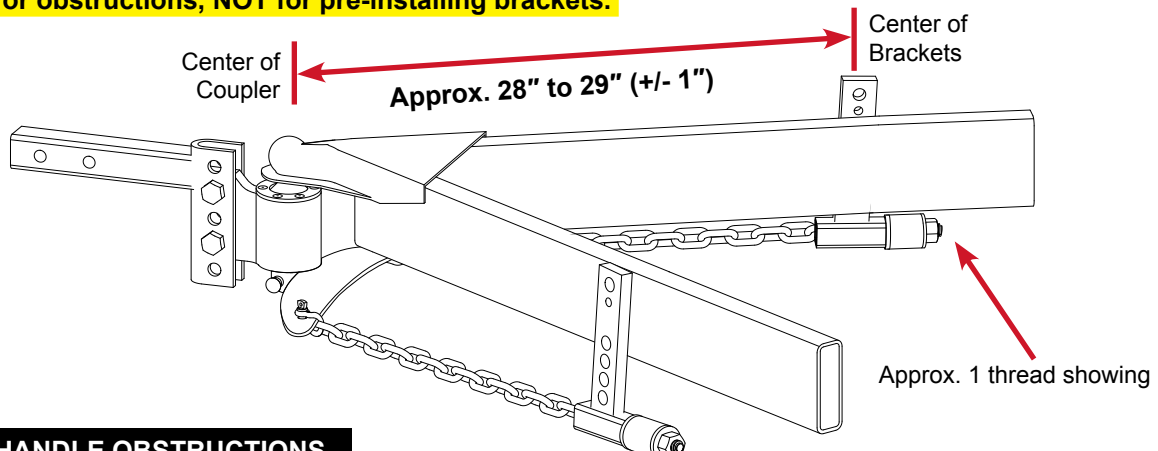

HOW TO HANDLE OBSTRUCTIONS

If you have any OBSTRUCTIONS or fixtures on the frame that get in the way of the frame brackets, there are two options:

1. **Move/adjust the obstructing object forward or backward so it is out of the way.** Some items like propane tanks and batteries can be moved or raised using off-the-shelf frames or brackets. See your local Authorized Andersen Dealer for further help and options.
2. **Accommodate for the obstructions by removing or adding links to the WD tension chains** (on the shackle end). You can **SHORTEN** the chain (up to approx. 5 links, leaving 10 or more links) or **ADD several inches to the chain** (as many links as needed) with no adverse effect. If you do remove/add any chain links, be sure to remove/add the same number of links from both chains. Chain extensions (Part #3366) can be ordered through your authorized Andersen Dealer.

SHORTENING CHAINS: You can permanently remove chain links using bolt-cutters or other cutting equipment OR you can insert a heavy-duty threaded link between the chain and shackle to effectively shorten the chains without actually removing links — unused links will hang free. If you do not have bolt-cutters or other cutting equipment and want to permanently remove chain links, see your local Authorized Andersen Dealer for help.



CAUTION! Double-check around the trailer frame to see if there are any brake lines, gas lines, or wiring that could be damaged by installation of the frame brackets. If so, find a way to reroute them before final installation.

4-3. Make sure both chains are equal in length, and relatively straight (not twisted). Then, while keeping the chains tight, LOOSELY attach (barely hand-tighten) both pairs of frame brackets to the tongue of the trailer using the positioning below. **Do not insert the set screws yet.**

NOTE: If you are installing multi-size frame brackets, use the bolt holes that are closest to your frame size

(see picture at right for sizing on universal brackets).

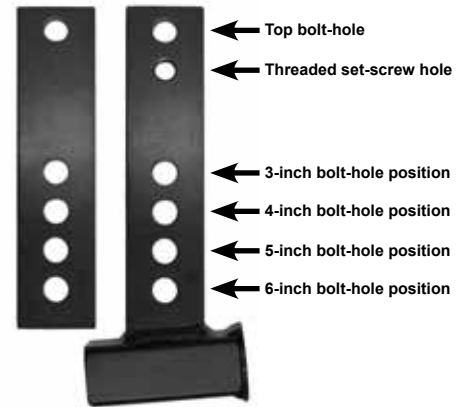

ENSURING CORRECT BRACKET INSTALLATION

Correct Bracket Positioning

The larger brackets attached to the tension chains should be placed on the OUTSIDE of the trailer frame. As discussed in installation step 4-3, start by loosely attaching these outside brackets to the smaller brackets placed on the INSIDE of the trailer frame.

Correct Bolt Installation Order

If installing 3"/4"/5"/6" universal brackets, 4-3/8" brackets, or 7"/8" brackets, begin by loosely attaching each set of inside and outside brackets with a frame bracket bolt and nut through the TOP bracket holes with the nut on the inside. Then, use a second frame bolt and nut through the first set of bracket holes below the lower edge of your trailer frame. **Do not install the pointed set screws until installation step 4-6.**

If installing RAISED 3"/4"/5"/6" brackets, begin by loosely attaching each set of inside and outside brackets with a frame bracket bolt and nut through the BOTTOM bracket holes with the nut on the inside. Then, use a second frame bolt and nut through the first set of bracket holes above the upper edge of your trailer frame. **Do not install the pointed set screws until installation step 4-6.**

CORRECT INSTALLATION ORDER FOR:

- 3"/4"/5"/6" (Universal) Brackets
- 4-3/8" Brackets
- 7"/8" Brackets

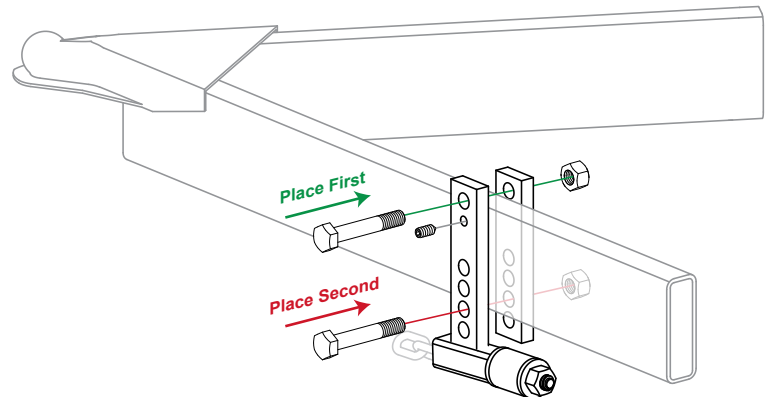

CORRECT INSTALLATION ORDER FOR:

- RAISED 3"/4"/5"/6" Brackets

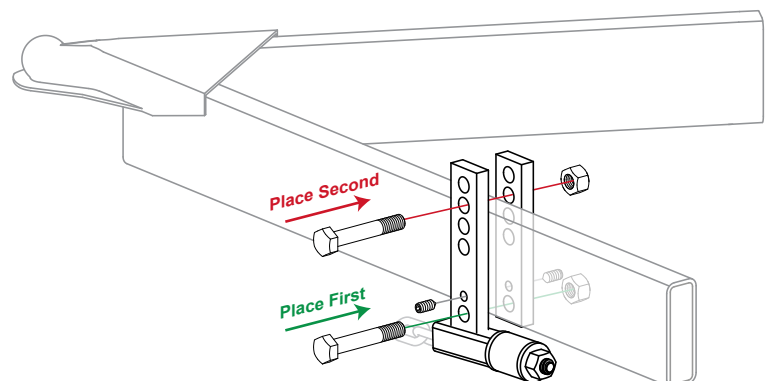

4-4. Once you have your brackets loosely connected, pull the top of the bracket sets away from the coupler until the top and bottom bolts rest on the frame **and the chains are tight** — the brackets will now be angled as seen below. Now tighten down all four bracket bolts using two 15/16" sockets or wrenches.



NOTE: Brackets should end up at an angle on your trailer frame

4-5. Make sure all brackets are clamped tightly — we recommend around 75-90 ft-lbs of torque depending on your frame.

IMPORTANT: Some lighter frames may begin to crush if torqued too high, so be aware of your frame's capabilities.

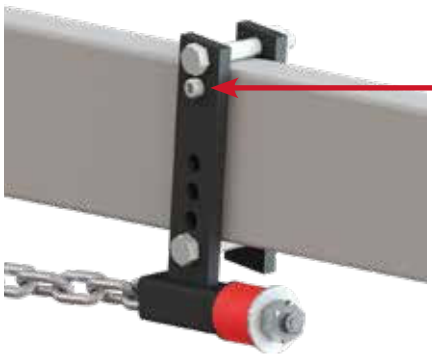

4-6. Using a 5/16" allen ratchet or allen wrench, screw in all set screws until they **barely touch** the trailer frame. Then, proceed to tighten them 1-1/2 to 2 more full rotations. If you find that your brackets tend to shift, you can use one of the following optional set screw installation methods for a more secure connection.

NOTE: If you are installing a kit with Raised 3"/4"/5"/6" brackets, you will use four set screws — one set on the outside brackets and one set on the inside brackets as shown on page 8.

C-CHANNEL FRAMES

If your trailer has a 'C-channel' style frame as shown in the illustration on the right, you will need to install the set screws or brackets using one of the two optional methods that follow. Both optional methods are designed to help ensure a secure hold for the brackets of your WD kit.

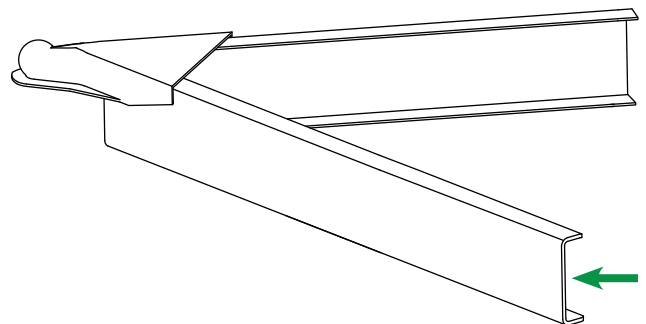

1. OPTIONAL SET SCREW INSTALLATION - PRE-DRILLING (for both Regular and C-Channel frames)

A good option to strengthen and secure the hold of the set screws is to pre-drill a 7/16" hole into the frame where the set screws will be located. Before drilling, insert the set screw into the frame bracket and turn it until the tip makes contact with the frame, then turn it a little more to apply pressure and make a mark on the trailer frame. Remove the set screw and drill a hole in the frame at the point you marked. After drilling, replace and tighten the set screws into the hole to prevent the bracket from slipping.

2. OPTIONAL FRAME BRACKET INSTALLATION - WELDING (for both Regular and C-Channel frames)

Using the services of a certified welder, another option is to add a 2" weld along the lower back side of both outside frame brackets (on the same side the red spring is on). This will give you a very secure installation of the frame brackets without the need for set screws. Before welding you will need to grind the paint off of the area to be welded.

For best performance, you will want to weld the brackets at an angle that allows the straightest travel of the chain through the outside bracket.

NOTE: You do not need to weld the inside frame brackets. Should you decide to sell your trailer later, the weld could be easily removed by prying the bracket away and grinding off the leftover weld.

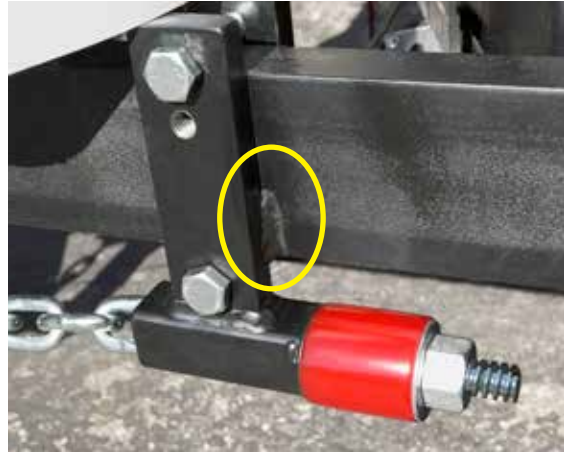

NOTE: AS WITH ANY WEIGHT DISTRIBUTION HITCH, DO NOT USE THE ANDERSEN WD HITCH WITH ANY KIND OF SURGE BRAKE SYSTEM

'Y' STYLE TRAILER FRAMES

The Andersen 'No-Sway' Weight Distribution Hitch can accommodate nearly all 'Y-style' trailer frames. In some cases you may need to remove or add a few chain links to allow installation at the optimum position on the trailer frame. In some cases you may need to install the unit using just the outside frame brackets — bolting them to each other rather than to the inside frame brackets. Use the examples below as a guide.

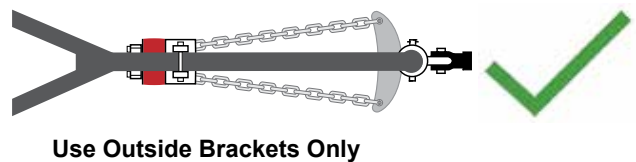
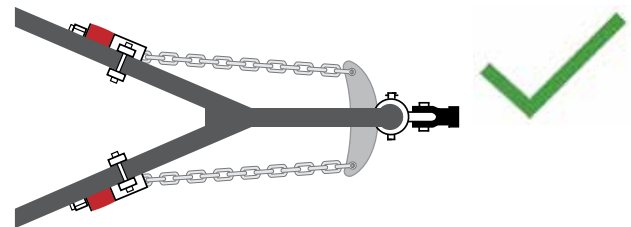
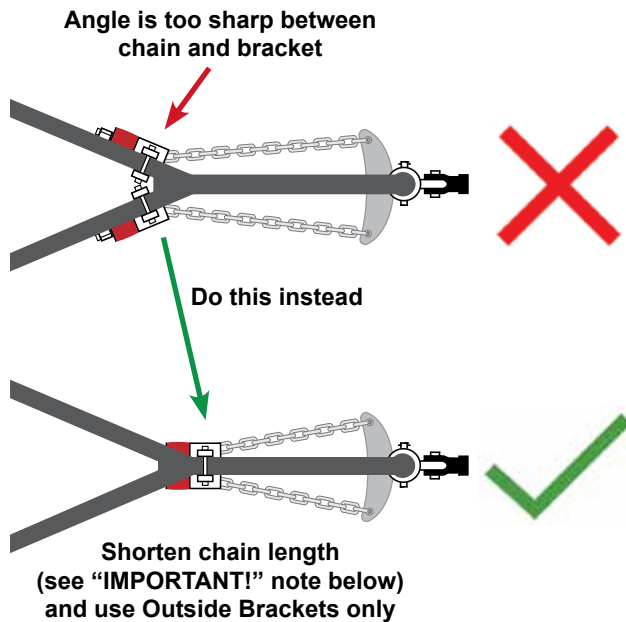

IMPORTANT! You can **SHORTEN** the chain (up to approx. 5 links shorter) or **ADD** several inches to the chain (as many links as needed). For more information, see page 8 under "How to handle obstructions."

NOTE: If you do remove/add any chain links, be sure to remove/add the same number of links from both tension chains. If you have any questions about a particular installation please call our customer service center at 800-635-6106.

SECTION 5: SETTING THE TENSION

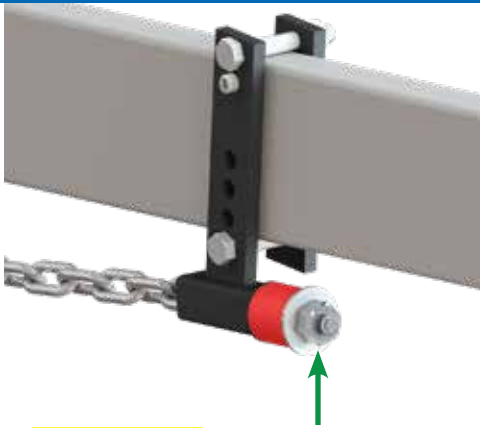

IMPORTANT - BEFORE USING A WRENCH, hand-tighten both Tension Nuts until the chains are tight

5-1. Once the frame brackets are firmly and securely in place, **make sure your chains are still tight**. Then, using the 1-1/4" socket (provided), **HAND-TIGHTEN** both Tension Nuts as much as you can — this is now your starting point when tightening with a wrench. Now, using a wrench with the provided 1-14" socket, tighten both Tension Nuts another 3–4 threads. The red urethane springs will be compressed and have a little bit of a curved edge.

5-2. Lower the trailer and set the full weight of the trailer onto the ball. The front and back end of your trailer should now be close to level.

To fine-tune the weight distribution, you can tighten or loosen both Tension Nuts one thread at a time. Although it is not crucial, it is a good practice to tighten or loosen both of the Tension Nuts about the same amount.

See Section 6 for further checking and adjustment.

SECTION 6: CHECKING AND ADJUSTING THE TENSION

6-1. For most circumstances, you will be able to see just how well the installation and adjustment is going by standing back and looking at how level the trailer and tow vehicle are. The trailer should be level, while the tow vehicle should be pretty close to level. If either is drastically uneven, follow the troubleshooting steps on the following page.

IMPORTANT Trying to get the Tow Vehicle perfectly level is **NOT** necessary — you just don't want to be too extreme in either direction (too much towards the tow vehicle's front axle or too much towards the rear axle). After hundreds of installations we have found that it is quite effective to basically "sight level" the tow vehicle and get it as close to level as you can by tightening/loosening the Tension Nuts. We have illustrated some good and bad examples below:

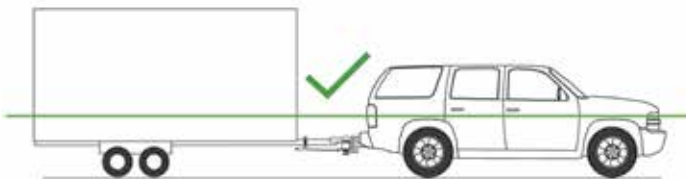

GOOD: Trailer and tow vehicle are level



GOOD: Trailer is level, rear of tow vehicle is a little lower than front

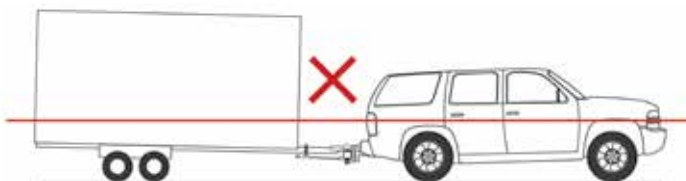

BAD: Trailer is not level and rear of tow vehicle is a lot lower than front
1. Check the Load 2. Check Installation 3. Tighten Tension Nuts

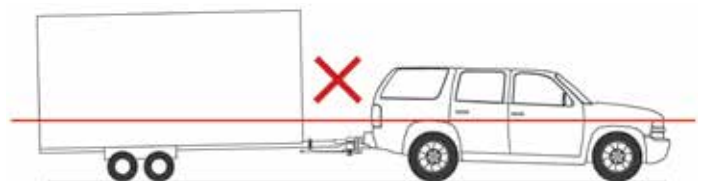

BAD: Trailer is not level and back of tow vehicle is higher than front
1. Check the Load 2. Check Installation 3. Tighten Tension Nuts

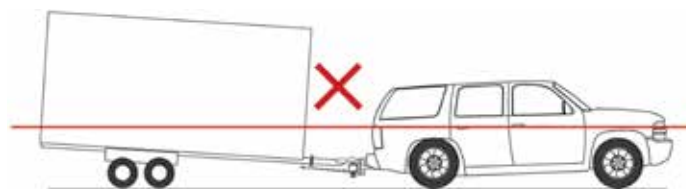

BAD: Far too much weight on back of tow vehicle Trailer is severely off-level
1. Check the Load 2. Check Installation 3. Tighten Tension Nuts

REMEMBER Any time your load changes in the towing vehicle or trailer, re-check to see how level you are and make adjustments as needed. Also, check the tightness of all nuts and bolts often and re-tighten as necessary.

TROUBLESHOOTING HOW LEVEL YOU ARE

- 1. Check the Load.** Is there too much weight in the trailer or tow vehicle? If not, perhaps the load is too far to the front or back of the trailer or tow vehicle and needs to be distributed better.
TIP: It's better to keep the weight shifted towards the front of the trailer than the back... approximately 60% in the front and 40% in the back.
- 2. Check Your Installation.** Start again from Step 1 and double-check each of the installation steps.
- 3. Adjust the Tension Nuts.** Drop the trailer jack to remove heavy tension from the chains. Then, tighten or loosen each tension nut one thread at a time and check the result by raising the trailer jack and putting the full weight of the trailer back on the chains. Tightening will move the weight distribution towards the front axle of the tow vehicle, loosening the Tension Nuts moves the weight towards the rear axle of the tow vehicle. To determine if the bolts are tightened the same amount, count the number of threads showing on the end of the chain bolts.

Having trouble installing? If you have read through the safety information on pages 3 & 4, and followed all of the installation instructions well, but are still having difficulty with the installation, please contact your local Authorized Andersen Dealer, or visit our help website at help.AndersenHitches.com, or call our customer service center at 1-800-635-6106.

UNHOOKING THE TRAILER FROM THE TOW VEHICLE

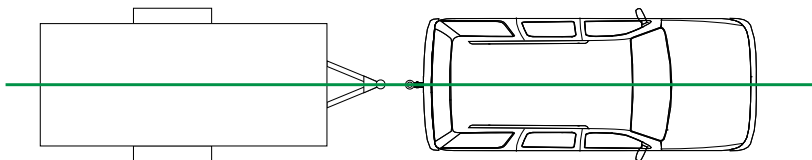

For convenience in hooking back up LATER: Before you unhook the trailer from the tow vehicle, try to park the trailer and tow vehicle as close to evenly in line as possible (as shown at left).

1. Once you are parked, chock the tires of your trailer and remove your safety chains (not the Tension Chains).
2. Use your trailer's jack (or support leg) to lift the trailer and take the weight off of the back tires of the tow vehicle.
3. Make a note of how many threads are showing. Using the 1-1/4" socket, loosen both Tension Nuts.
4. Remove the pin and clip attached to the bottom of the ball and Tension Plate (fig. 1).
5. Remove the TensionPlate — you can leave the chains and shackles attached to it (fig. 2).
6. In some cases you may need to lower the coupler, placing the weight of the trailer back onto the ball so it centers itself in the coupler, then raise the coupler back up and completely off of the ball.
7. Now you have the option to use the Weight Distribution ball as a standard hitch ball for towing other trailers (as shown in fig. 3).

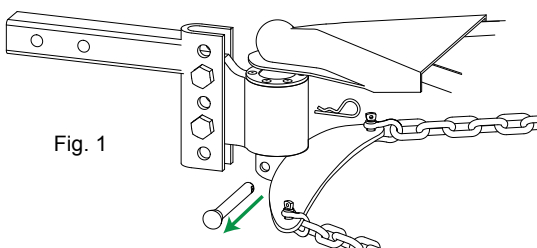

Fig. 1

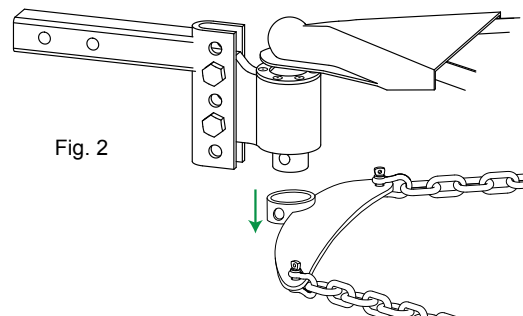

Fig. 2

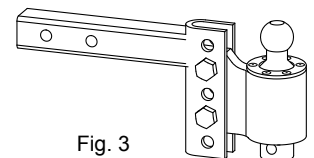
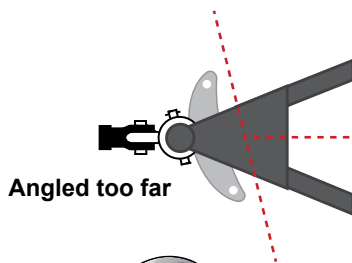

Fig. 3

HOOKING THE TOW VEHICLE BACK UP TO THE TRAILER

1. Using your trailer's support leg or jack, lower the trailer coupler onto the ball — make sure there is almost no weight on the ball, and secure the coupler latch.
2. Use the trailer jack to raise the back of the tow vehicle up 1-1/2".
3. Attach the Tension Plate (with chains and shackles attached) and pin it securely in place.
4. Using the 1-1/4" socket, tighten both Tension Nuts (make sure the same number of bolt threads are showing as when you loosened them).
5. Lower the trailer and set the weight of it fully on the ball. Go back to Section 6 and check how level the Trailer and Tow Vehicle are. Make adjustments if necessary.
6. Re-hook up the trailer's safety chains (not the Tension Chains) to the tow vehicle.

TENSION PLATE ANGLED TOO FAR?



If you are unable to back up your tow vehicle to the same angle as when you unhooked your trailer or the tension (triangle) plate is no longer perpendicular to the trailer, then follow the procedure below to straighten out the tension plate.



IMPORTANT: DO NOT USE A HAMMER TO TRY AND LINE THE PLATE UP, IT WILL DAMAGE THE PLATE

Lower the trailer coupler onto the WD ball, secure the coupler and raise your jack out of the way. Unhook both chains from the tension plate and secure the tension plate to the bottom of the ball.

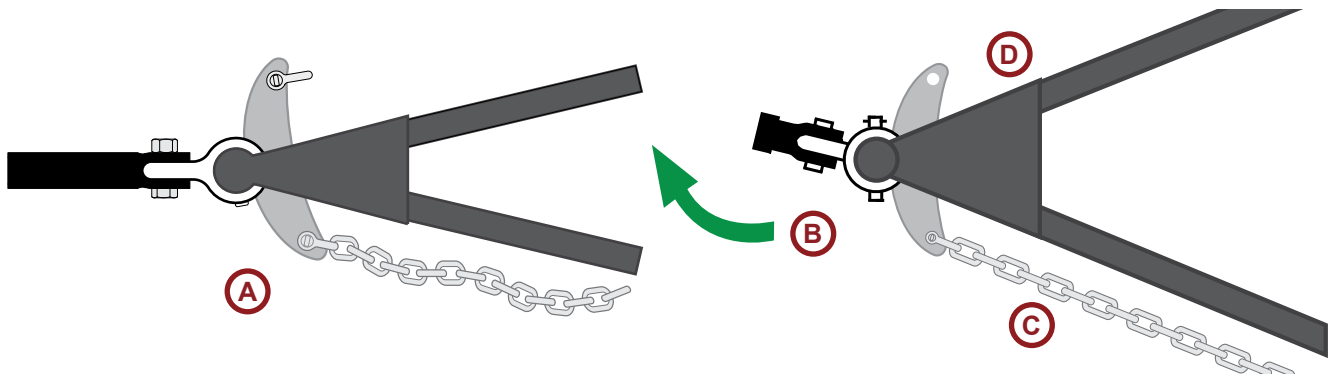

Attach the chain to the tension plate on the side that is **closest** to the frame brackets (A) — don't adjust the tension nut yet.

Drive forward in the opposite direction of the chain that is attached (B) until the chain is tight (C). This will turn the tension plate and bring it close to perpendicular.

Use your trailer jack to raise the coupler until there is almost no weight on the ball. Hook up the chain on the other side of the tension plate (D) and set the correct tension with both tension nuts.

REMEMBER Any time your load changes in the towing vehicle or trailer, re-check to see how level you are and make adjustments as needed. Also, check the tightness of all nuts and bolts often and re-tighten as necessary.

Questions or Concerns? If you have read the safety information on pages 3 & 4 and followed all of the installation instructions well, but are still having difficulty with the installation or hook up, please contact your local Authorized Andersen Dealer, visit our website at help.AndersenHitches.com or call our customer service center at 1-800-635-6106.

OPTIONAL ADD-ONS FOR YOUR WEIGHT DISTRIBUTION HITCH

More than one trailer?

Add a WD Trailer Kit to your other trailers so you can quickly and easily switch between trailers with your Weight Distribution system.

Includes all mounting hardware shown. Available in optional bracket sizes — shown below. 2" and 2-5/16" tapered balls are also available to fit different size trailer couplers.



#3372
WD Trailer Kit

Includes tension plate, chains, washers, nuts, brackets and mounting hardware. (Specify bracket size.)



#3382, #3354
Tapered WD Ball

2" Ball (#3382)
2-5/16" Ball (#3354)

AVAILABLE BRACKET SETS

Each bracket set includes 2 inside brackets, 2 outside brackets, 4 bolts, 4 nuts and 2 (or 4) set screws

(Extended 3"/4"/5"/6" Bracket Set #3359-XTD is available for use on trailers with underslung couplers)



#3361
4-3/8" Bracket Set



#3359
3"/4"/5"/6" Bracket Set
(multi-frame)

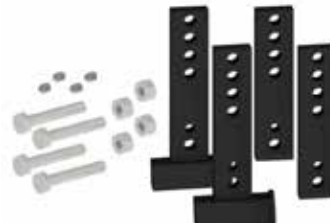

#3369
3"/4"/5"/6" RAISED Bracket Set
(for low trailer frames only)



#3387
7"/8" Bracket Set



IMPORTANT DO NOT use above Pins & Clips in place of the bolts & nuts when attaching the WD Ball Housing to the WD Hitch rack.

#3352, #3352-25
2" x 2-5/16" Combo Ball

Use with your WD adjustable rack to pull other trailers when you don't need Weight Distribution



#3351, #3399, #3399-3
WD 8" Drop/Rise Rack

2" Shank 14K (#3351)
2-1/2" Shank 16K (#3399)
3" Shank 16K (#3399-3)



#3353, #3391, #3391-3
WD 4" Drop/Rise Rack

2" Shank 14K (#3353)
2-1/2" Shank 16K (#3391)
3" Shank 16K (#3391-3)



#3366
WD Chain Extensions

1 pair
(adds approx. 11.25" to overall chain length)

FIND MORE ACCESSORIES AND PRODUCTS AT www.AndersenHitches.com

Warranty Registration and Validation

Andersen Weight Distribution Hitch

To register your Weight Distribution Hitch, simply visit

www.AndersenHitches.com/register and complete your registration online.



Andersen Hitches Limited Warranty

PLEASE RETAIN YOUR ORIGINAL BILL OF SALE AS YOU WILL NEED TO PRESENT IT SHOULD YOU REQUIRE SERVICE UNDER THIS WARRANTY.

LIMITED LIFETIME WARRANTY: Andersen Manufacturing, Inc. (hereinafter referred to as "ANDERSEN") warrants specific Andersen brand products ("Products") purchased directly from Andersen or an Authorized Andersen Dealer, in accordance with the terms and conditions detailed herein for the periods indicated below.

⊗ WARNING: IF YOU PURCHASE AN ANDERSEN PRODUCT FROM AN UNAUTHORIZED DEALER, YOUR ANDERSEN WARRANTY WILL NOT BE VALID.

SCOPE OF WARRANTY: Commencing with the date of retail purchase and continuing for the periods specified in the Warranty Period table below, this Limited Warranty is extended to the original purchaser ("BUYER") only and warrants the Product against latent defects in materials and workmanship under normal use and service (rust, corrosion and ordinary wear and tear excepted) and is subject to the Exclusions and Limitations set forth below. A dated purchase receipt or bill of sale, or other proof of the purchase date, is required for Warranty service. If the Product is determined to be latently defective, ANDERSEN will, at its own discretion, replace or repair the Product and/or associated parts.

This Limited Warranty applies only to authentic Products manufactured and/or distributed by ANDERSEN. It does not apply to non-ANDERSEN supplied goods, even if they are packaged or sold with ANDERSEN branded Products or falsely identified as ANDERSEN Products. While some non-ANDERSEN supplied goods sold with an ANDERSEN Product may be covered by their own warranties, ANDERSEN, to the extent permitted by applicable law, provides such third-party products "AS IS".

EXCLUSIONS and LIMITATIONS: IF YOU PURCHASE AN ANDERSEN PRODUCT FROM AN UNAUTHORIZED DEALER, YOUR ANDERSEN WARRANTY WILL NOT BE VALID, please use our List of Authorized Dealers or our Authorized Dealer Locator.

BUYER is responsible for maintenance checks to the Product on a regular basis. It is also the responsibility of the BUYER to have the trailer braking system checked and maintained on a regular basis. Damages resulting from failure to perform these maintenance checks shall not be covered by this Warranty.

As the condition of trailers and vehicles used with the ANDERSEN Product is beyond ANDERSEN's control, ANDERSEN cannot and does not warrant or assume liability for damages incurred to trailers or vehicles during use of the Product.

ANDERSEN does not warrant against discontinuation of Product, defects in items or components not manufactured by ANDERSEN, or against damages resulting from use of such non-ANDERSEN made products or components. ANDERSEN passes on to BUYER the warranty it received (if any) from the maker of any non-ANDERSEN made products or components.

This Limited Warranty does not apply to any Product upon which repairs have been affected or attempted by persons other than those in possession of written authorization from ANDERSEN.

Additionally, this Limited Warranty does not apply with respect to any of the following:

1. Defects or damage resulting from improper installation, unauthorized alteration, unreasonable use, or improper maintenance including, but not limited to loading the Product beyond the Product's rated load capacity.
2. Defects or damage caused by an accident, sudden impact arising from a collision, or other abnormal occurrences.
3. Defects or damage caused by fire, smoke, flood, water damage, lightning, or other acts of nature/acts of God.
4. Defects or damage caused by abuse, misuse, negligence, accident, unauthorized product modification or service, or failure to observe the instructions contained in the manual furnished at the time of original purchase.
5. Damage caused during shipment or handling.
6. Products purchased from anyone other than ANDERSEN or an Authorized Andersen Dealer. If you are uncertain as to whether a dealer is authorized, please visit our List of Authorized Dealers or contact our Customer Service Department.
7. Products that have been altered or repaired by anyone other than ANDERSEN or an Andersen Authorized Dealer in a manner that has affected the product's performance, stability or reliability.
8. Any accessories or products attached to or used with ANDERSEN Products
9. Packing materials and cosmetic items like stickers.
10. Parts which have prescribed useful lives dependent upon the degree of their use, such as rubber pads, duffel bags, chemical products, etc.
11. Maintenance, cleaning or periodic check-ups.
12. Loss of keys to ANDERSEN's Stainless Steel Locking Pins.

THIS WARRANTY IS EXCLUSIVE. To the extent allowed by law, ANDERSEN shall not be liable for any incidental, consequential, or any other damages including, without limitation, breach of any implied warranty, merchantability, or fitness of the Product for a particular purpose. The sole and exclusive obligation of ANDERSEN shall be to repair or replace the defective Product in the manner stated above. ANDERSEN shall not have any other obligation with respect to the Product or any part thereof, whether based on contract, tort, strict liability, or otherwise. It is understood that the seller's liability, whether in contract, in tort, under any warranty, in negligence or otherwise, shall not exceed the return of the wholesale amount of the purchase price paid by the BUYER. Under no circumstances, whether based on this Limited Warranty or otherwise, shall ANDERSEN be liable for incidental, special, or consequential damages. The price stated for the Product is considered in limiting ANDERSEN's liability.

ANDERSEN's employees', representatives' or Dealers' ORAL OR WRITTEN STATEMENTS DO NOT CONSTITUTE WARRANTIES, shall not be relied upon by BUYER, and are not a part of the contract for sale or this limited warranty.

This warranty does not include labor charges nor does it include transportation charges for returning the Product to the consumer. Removal, shipping and installation of the replacement Product or replacement parts shall be at BUYER's expense.

WEIGHT DISTRIBUTION HITCH WARRANTY PERIOD (from date of purchase): Hitch – 1 Year / Brake Material Cone – Lifetime

OBTAINING WARRANTY SERVICE: For warranty service and returns please visit our website and click on "Warranty" at the bottom of the page or call our customer service department at 1-800-635-6106. Select warranty claims can be submitted digitally through the help.andersenhitches.com website.

ANDERSEN HITCHES



Premier Towing Products

See our full line of towing products at
www.AndersenHitches.com



Aluminum Rapid Hitch
Greaseless & Standard
2" or 2-1/2" shank available



Ultimate Trailer Gear Super EZ Bag
for dual-axle bumper pull trailers
(additional Ultimate Trailer Gear Bags available)

12- pc kit includes: 4 EZ Blocks, 2 Camper Levels
with 2 TUFF Chocks, 1 Rapid Jack with 1 Rubber
Mat, 1 Clean Step, and a Sturdy Duffle Bag



EZ Adjust Hitch & EZ HD
from 10K to 16K Heavy Duty
2", 2-1/2", or 3" shank available



Camper Leveler
Level your trailer on the first try!
Each kit includes chock and leveler

Kingpin to
Gooseneck ball



Kingpin to
Rail mount

Ultimate Connection 5th Wheel Hitch
Smoothest ride for 5th Wheel RV's
Connects your Kingpin to a Gooseneck ball
or standard Rails



EZ Block
Tough jack block works with post jacks,
scissor jacks, pad jacks, and more!

SUPPORT USA JOBS



Made in USA



www.AndersenHitches.com • 1.800.635.6106